

**Montageanleitung
DORMA
HSW-GE BOX 5
Schiebeflügel mit Schloss
und Stirnfeststeller**

**Mounting instruction
DORMA
HSW-GE BOX 5
Sliding panel with lock
and end-mounted slide bolt**

**Inhaltsverzeichnis:
Index of contents:**

S. 2	1. Zeichenerklärung / explication of symbols
S. 2	2. Montagewerkzeug / requisite tool
S. 2	3. Lieferumfang / scope of delivery
S. 3	4. Glasbearbeitung / glass preparation
S. 3	5. Vorbereitung der Beschläge / preparation of patch fittings
S. 4	6. Grundmontage der Beschläge / basic installation of patch fittings
S. 5	7. Montage der Kappen bei den Eckschlössern / installation of cover caps by the patch lock
S. 5	8. Montage der Rosetten Unterteile / installation of lower parts of the roses
S. 6	9. Montage des Profilzylinders / installation of profil cylinder
S. 6	10. Montage Rosetten Kappen / installation of cover caps for roses
S. 7	11. Montage der Laufrollen / installation of rollers
S. 7/8	12. Montage der Flügel / installation of panels
S. 9	13. Glasflügel ausrichten / adjust the glass panels
S. 10	14. Montage der Exzenterbuchse / assembly of the eccentric bushing
S. 11	15. Montage der Abdeckkappen / installation of cover caps

**1. Zeichenerklärung:
1. Explication of symbols:**

- ① = Bauteil / Baugruppe
Component
- 1. ; 1.1 ; ... = Montagefolge
Mounting sequence

**2. Montagewerkzeug:
2. Requisite tool:**

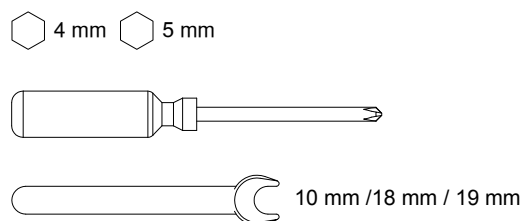

**3. Lieferumfang:
3. Scope of delivery:**

2x oberer Schiebe-Eckbeschlag
2x top sliding-corner patch fitting

1x unteres Eckschloss mit Exzenterbuchse
1x bottom corner lock with eccentric bushing

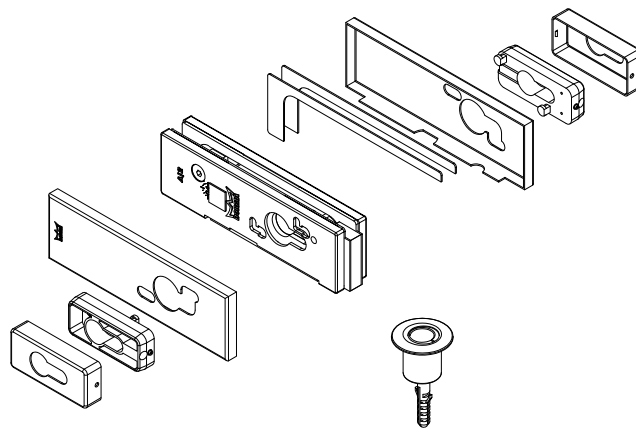
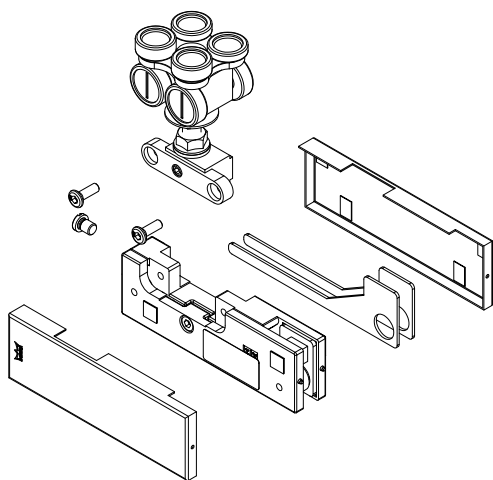

1x unterer Beschlag mit Stirnfeststeller und Exzenterbuchse
1x bottom patch fitting with end-mounted slide bolt and eccentric bushing

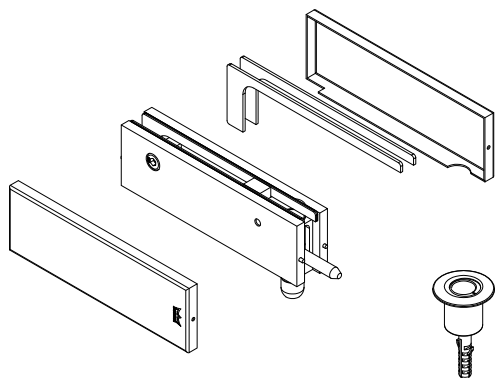

**4. Glasbearbeitung:
4. Glass preparation:**

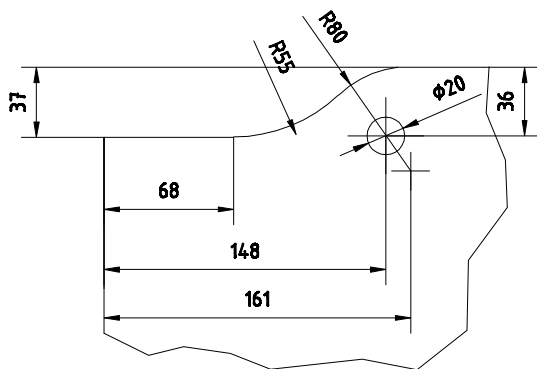

Glasausschnitt für:
- oberen Eckbeschlag GE 20 und GE 30
- unteren Eckbeschlag GE 10 für Bodenlager

Glass cut-out for:
- top patch fitting GE 20 and GE 30
- bottom patch fitting GE 10 for floor bearing

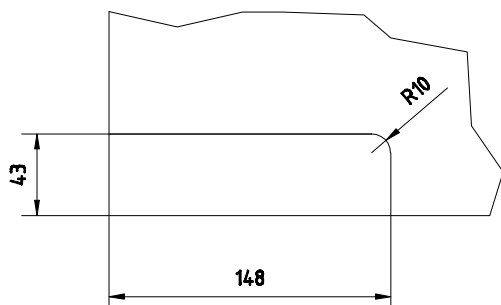

Glasausschnitt für:
- unteres Eckschloss
- Stirnfeststeller
- Gegenkasten für Stirnfeststeller

Glass cut-out for:
- bottom patch lock
- end-mounted sliding bolt
- keeper for end-mounted sliding bolt

**5. Vorbereitung der Beschläge:
5. Preparation of patch fittings:**

5.3 Folienstreifen abziehen und Zwischenlage aufkleben.
5.3 Pull-off backing tape and stick on the gasket.



5.2 Holz-/ Kunststoffklötze entsorgen
5.2 Dispose the spacer

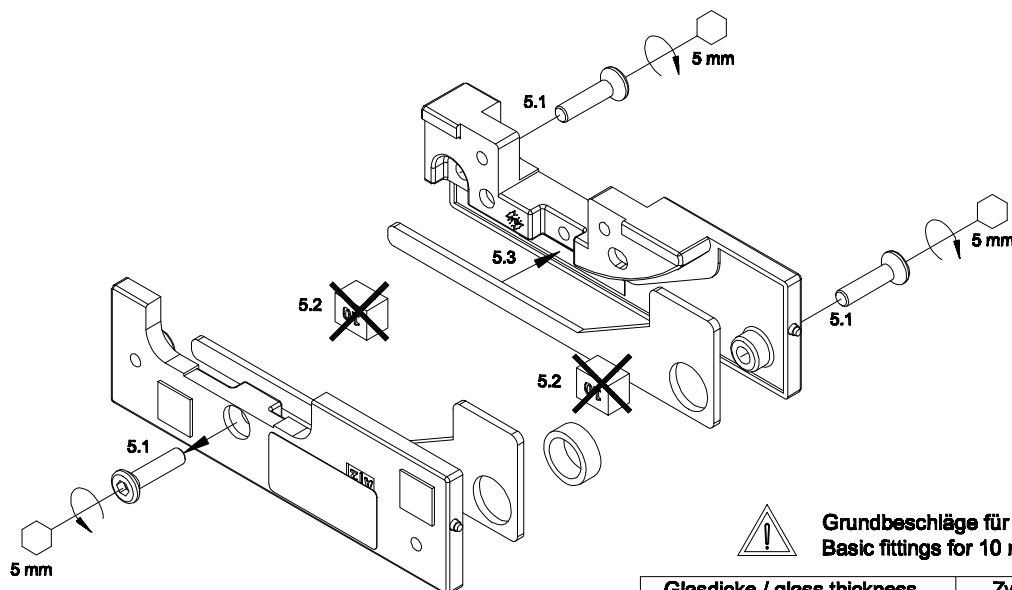

Grundbeschläge für 10 mm Glas
Basic fittings for 10 mm glass

Glasdicke / glass thickness	Zwischenlage / gasket
12 mm Glas	1 mm
10 mm Glas	2 mm
8 mm Glas	3 mm

**6. Grundmontage der Beschläge:
6, Basic installation of patch fittings:**

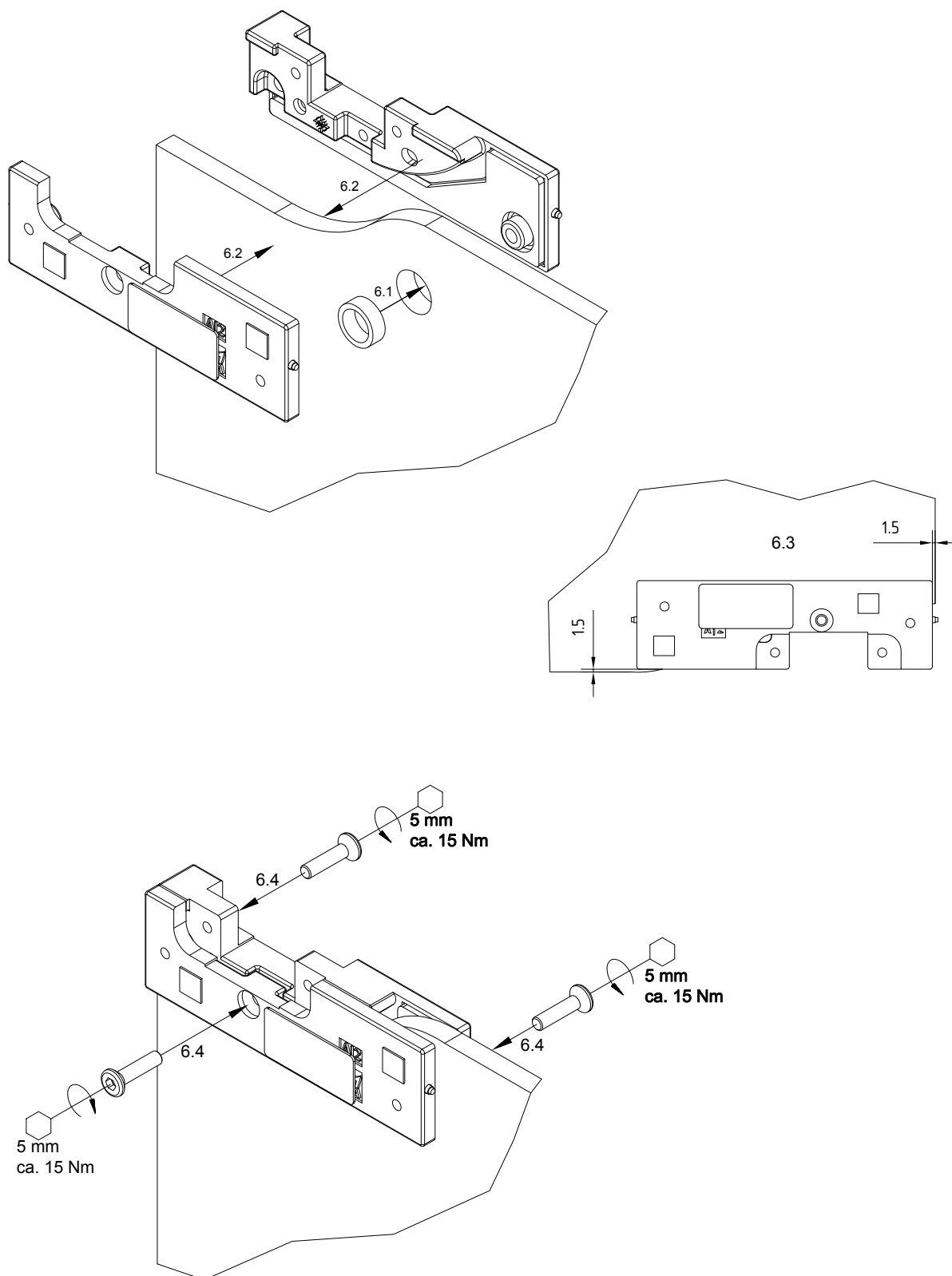

7. Montage der Kappen bei dem Eckschloss:

7. Installation of cover caps by patch lock:



Montage des Eckschlusses inkl. Profilzylinder, muss vor dem Einhängen des Flügels erfolgen, da sonst die Schraube zur Befestigung des PZ's nicht mehr eingesetzt werden kann!



Installation of patch lock and profil cylinder must be completed before the panel is attached, otherwise the profil cylinder fixing screw cannot be fitted!

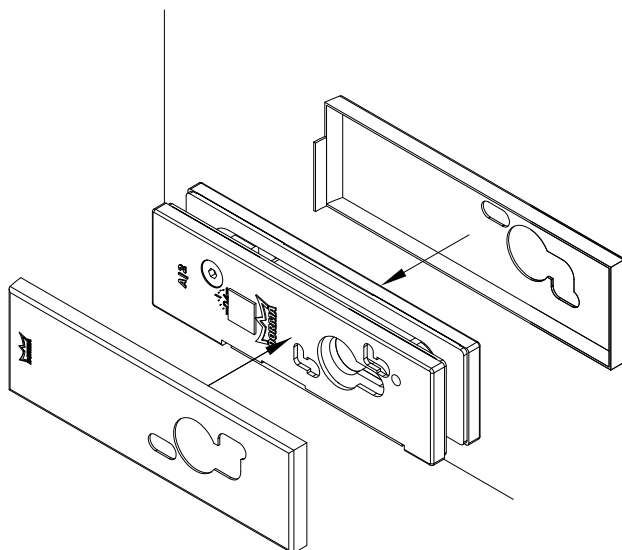

8. Montage der Rosetten Unterteile:

8. Installation of lower parts of the roses :

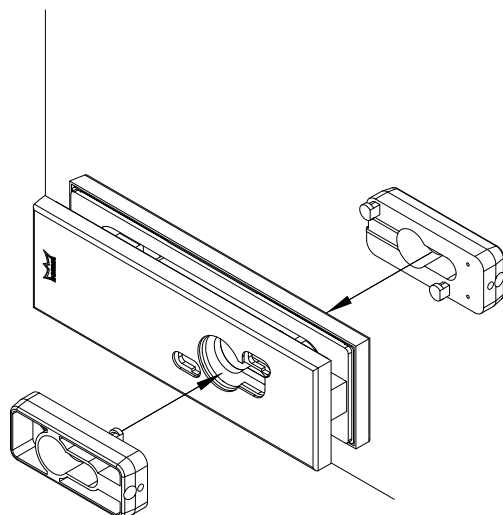
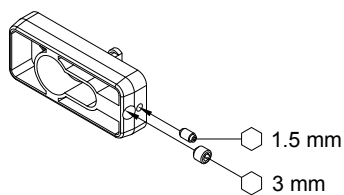

**9. Montage des Profilzylinders:
9. Installation of profil cylinder:**



Profilzylinder ist nicht im Lieferumfang enthalten.



Profil cylinder is not included in scope of delivery.

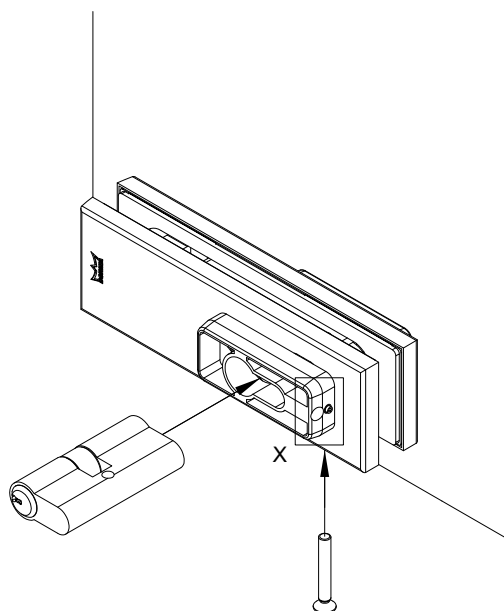

Detail X

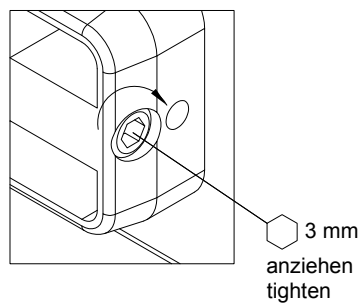

**10. Montage Rosettenkappen:
10. Installation of cover caps for roses:**

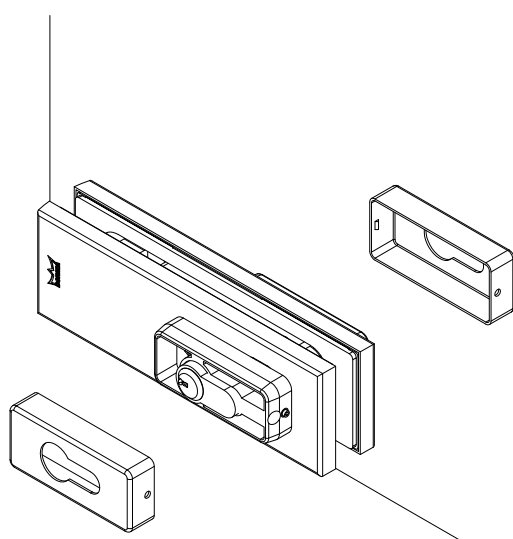

Detail Z

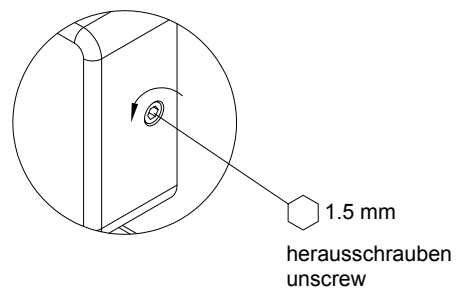

11. Montage der Laufrollen:
11. Installation of rollers:

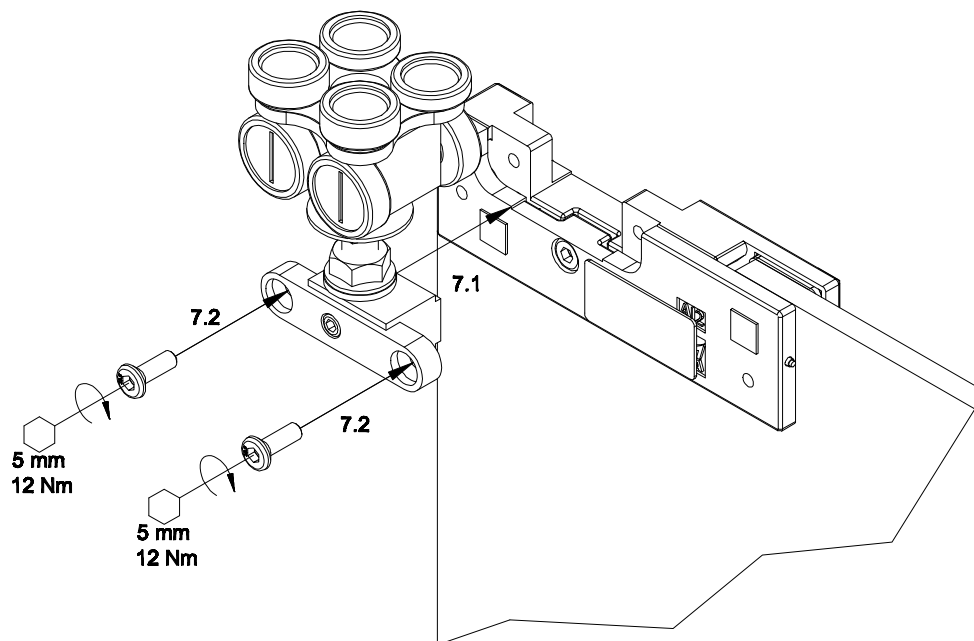

12. Montage der Flügel:
12. Installation of panels:



Das Revisionsstück muss für die Montage der Flügel demontiert werden!
The revision piece must be disassembled for the installation of the panels!

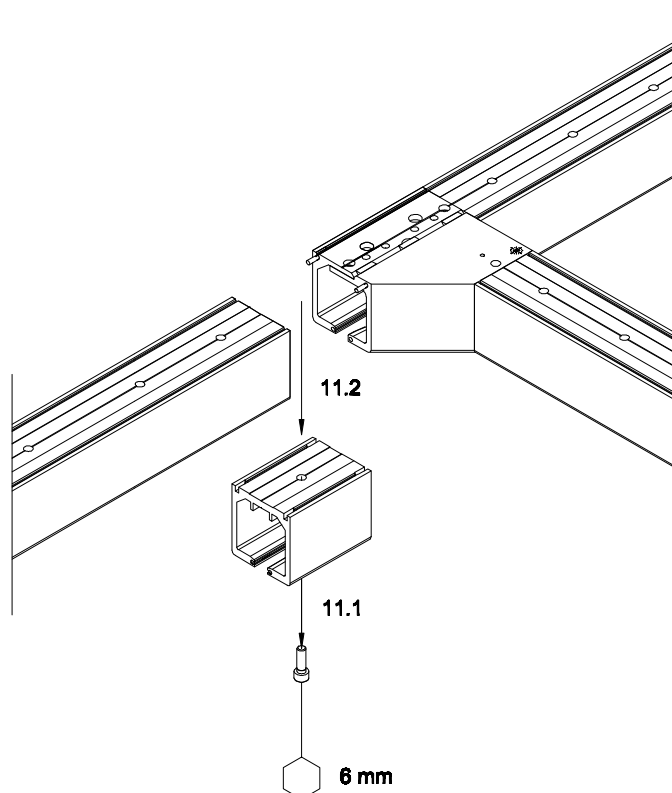

12.3 Flügel einhängen.
12.3 Fit the panels.



Bitte auf die Umlenkung der Rollen achten (siehe Anlagebezogene Montageanleitung, S. 12)!
Please pay attention to the turning device of the guide rollers (see system related installation instruction, P. 12)!

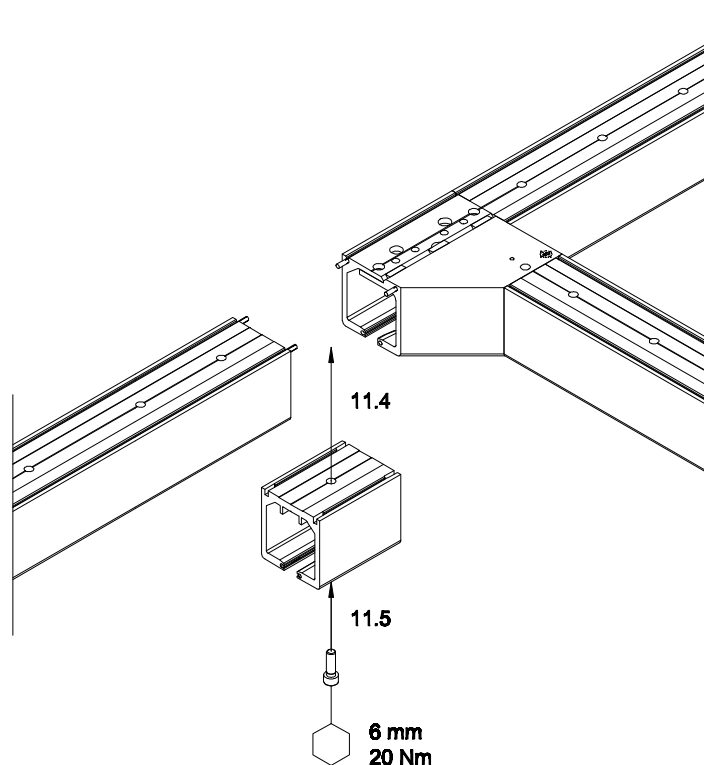
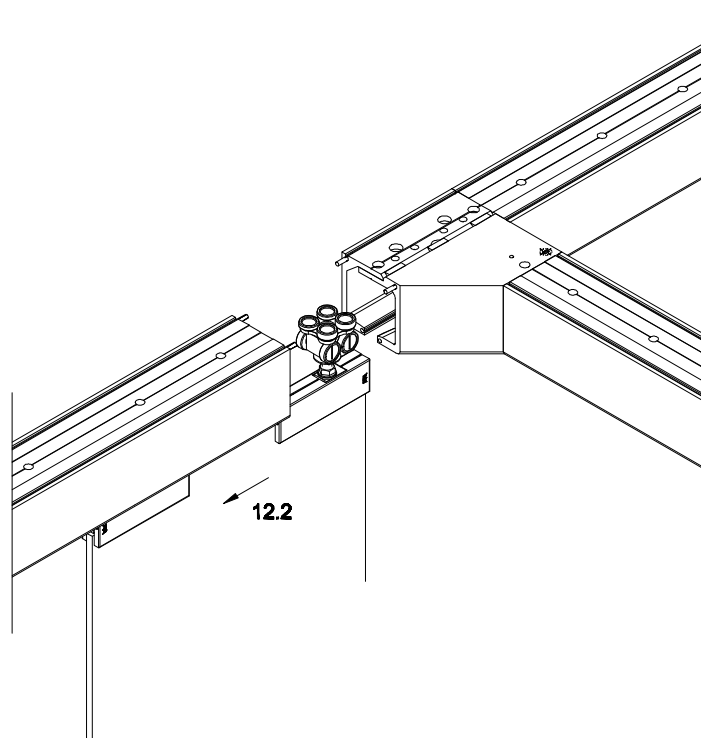

**13. Glasflügel ausrichten:
13. Adjust the glass panel:**

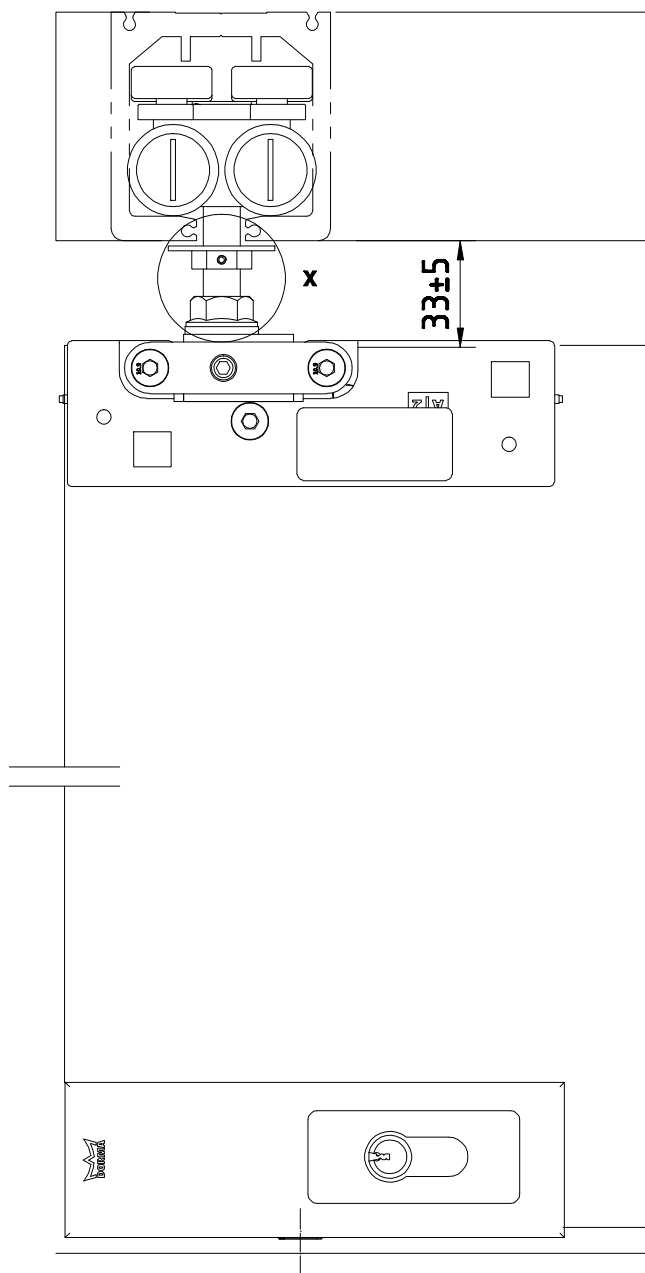

DETAIL X

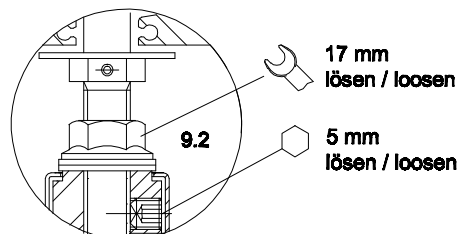

DETAIL X

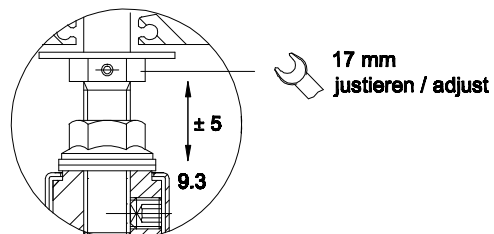

DETAIL X

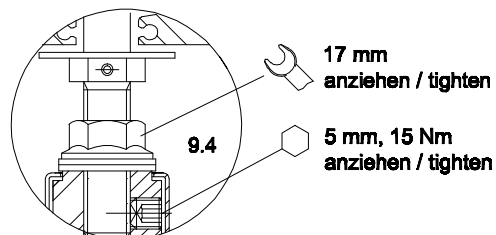

**14. Montage der Exenterbuchse:
14. Assembly of the eccentric bushing:**



Geeignete auf den Untergrund abgestimmte Ankersysteme verwenden!



Please use suitable anchoring systems according to foundation!

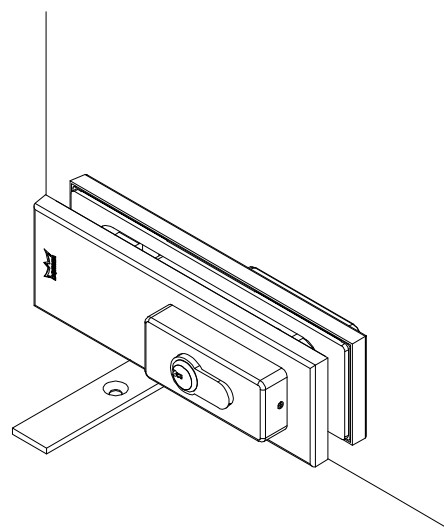
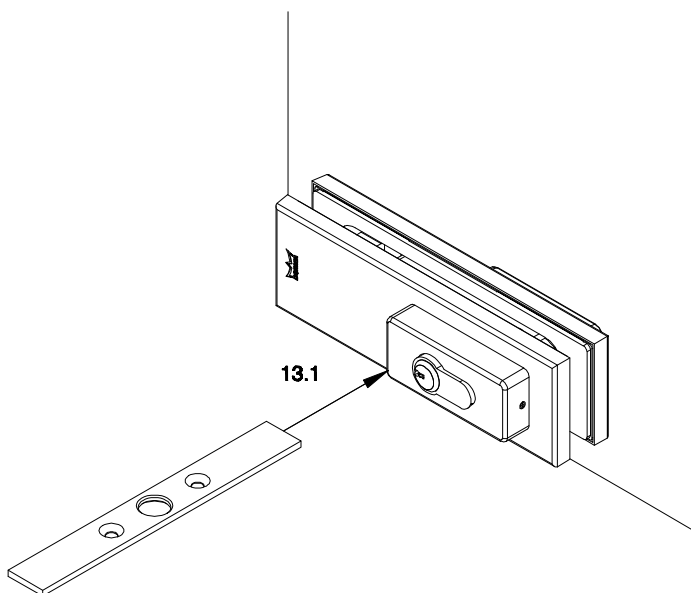

13.2 Bolzen in die Bohrung fahren, um die Position zu markieren.
13.2 Extend out the bolt to mark the position.

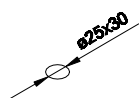

13.3 Loch bohren!
13.3 Drill the hole!



13.4 Buchse einsetzen und verschrauben!
13.4 Insert the bushing and screw on!

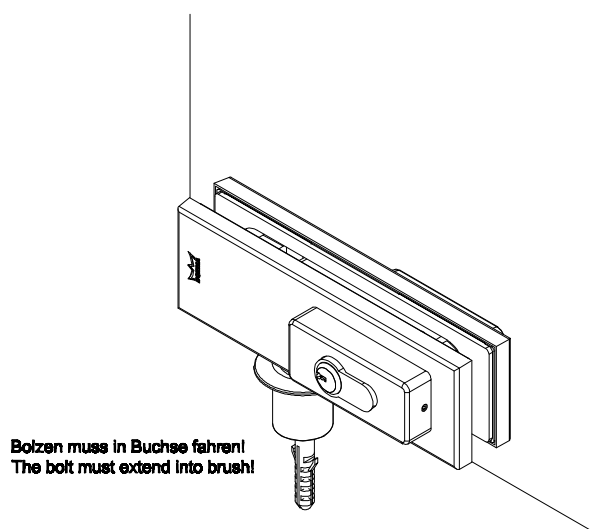

Bolzen muss in Buchse fahren!
The bolt must extend into bush!

15. Montage der Abdeckkappen:
15. Installation of cover caps:

