

EKU PORTA® 100

mod. GW

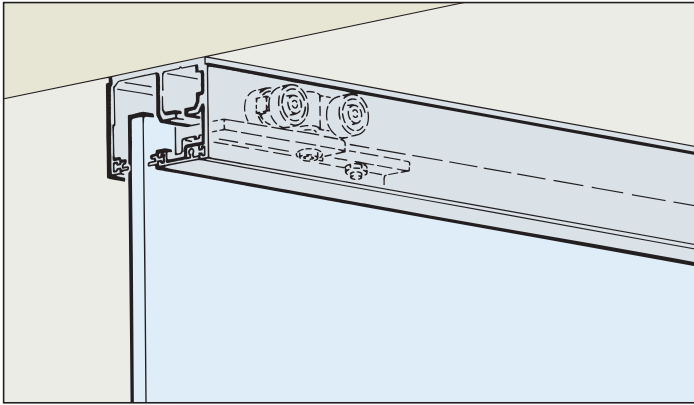

System: Laufschiene, Einbauhöhe 58 mm, einsetzbar bei aufgesetzter oder deckenbündiger Anwendung, für 1 Glastüre bis 100 kg.

System: Running track, installation height 58 mm, surface mounted or flush with the ceiling, for 1 glass door up 100 kg.

Système: Rail de roulement, hauteur d'installation 58 mm, montage en applique ou affleurant avec le plafond, pour 1 porte en verre jusqu'à 100 kg.

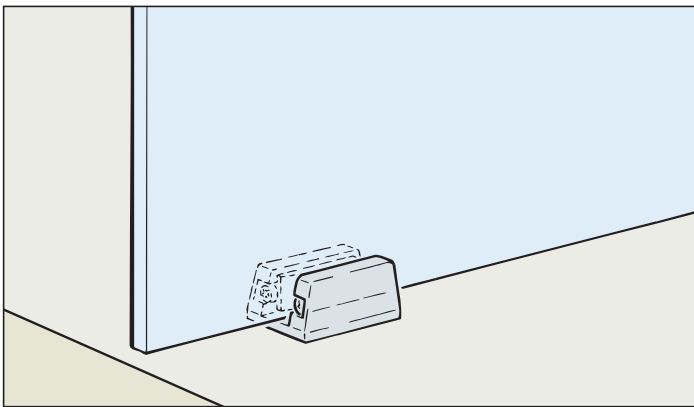

Einbaubeispiele / Mounting examples / Exemples de montage

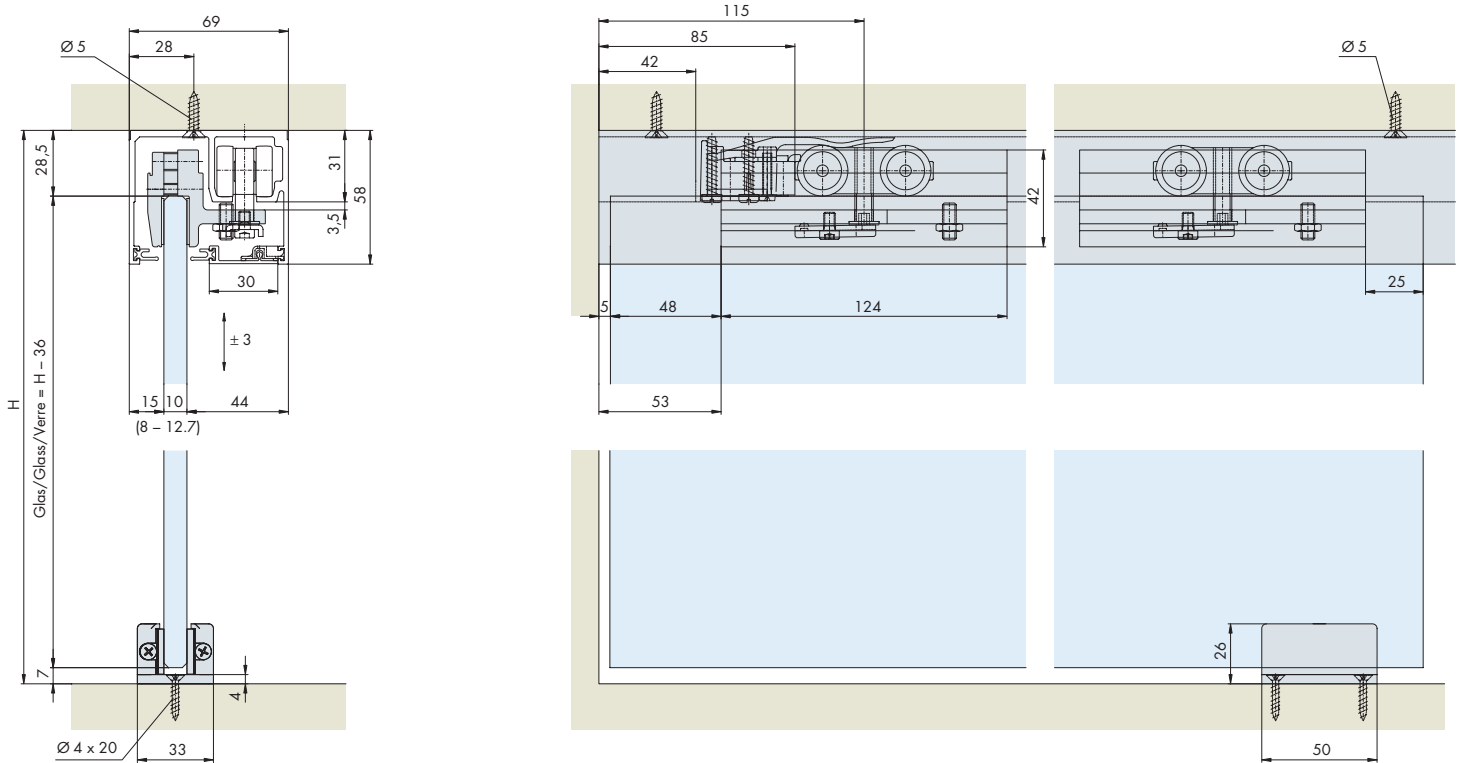

Einbaubeispiel deckenbündige Montage

Mounting example flush with the ceiling

Exemple de montage affleurant avec le plafond

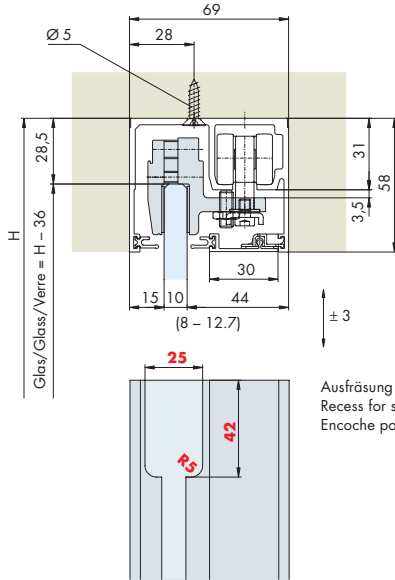

Ausfräsung zum Ein-/Ausfahren Laufwerk und Stopper
Recess for sliding running gear and stop in and out
Encoche pour introduire/sortir le chariot et la butée



Türgewichte
Door weights
Poids de portes 30

Garnituren / Sets / Garnitures

1 Türe Door Porte		No. 057.3091.071	
2x		2x	
1x		1x	
1x		12x	
1x			

Zubehör / Accessories / Accessoires

Laufschiene Alu, eloxiert, gelocht

Running track aluminium, anodized, pre-drilled

Rail de roulement en alu, anodisé, perforé

Gr./Size

Art. No.

2500 mm

057.3083.250

3500 mm

057.3083.350

6000 mm

057.3083.600*

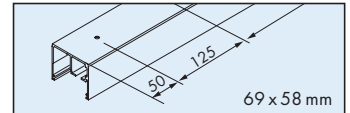

Blendenprofil Alu, eloxiert

Fascia profile aluminium, anodized

Profil de cache en alu, anodisé

2500 mm

057.3085.250

3500 mm

057.3085.350

6000 mm

057.3085.600*

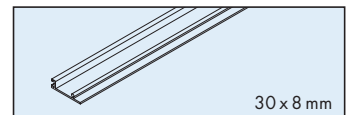

Sichtschutzdichtung, Kunststoff schwarz, in Rollen

Screening seal, black plastic, in rolls

Joint pare-vue, plastique noir, en rouleaux

20 m

057.3078.002

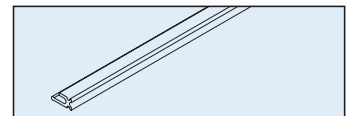

*min. 60 m

Türbearbeitung = rote Zahlen / Dimensions and drillings for door = red numbers / Traitement de portes = chiffres rouges

Sonderzubehör / Special accessories / Accessoires spéciaux: 26-29

EKU PORTA® 100

mod. GWF

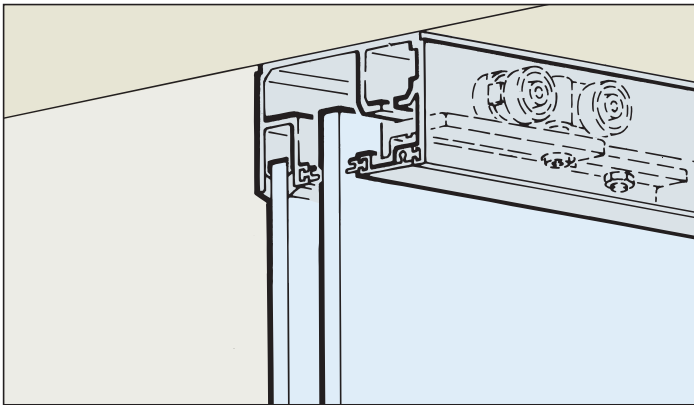

System: Laufschiene mit Festglashalterung, Einbauhöhe 58 mm, einsetzbar bei aufgesetzter oder deckenbündiger Anwendung, für 1 Glastüre bis 100 kg.

System: Running track with fixed glass support profile, installation height 58 mm, surface mounted or flush with the ceiling, for 1 glass door up to 100 kg.

Système: Rail de roulement avec porte-vitre fixe, hauteur d'installation 58 mm, montage en applique ou affleurant avec le plafond, pour 1 porte en verre jusqu'à 100 kg.

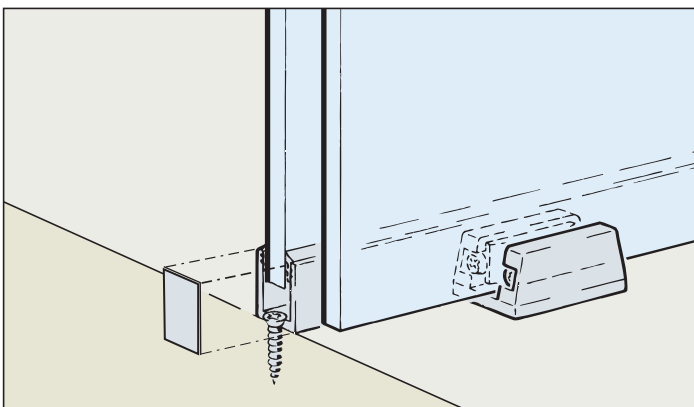

Einbaubeispiele / Mounting examples / Exemples de montage

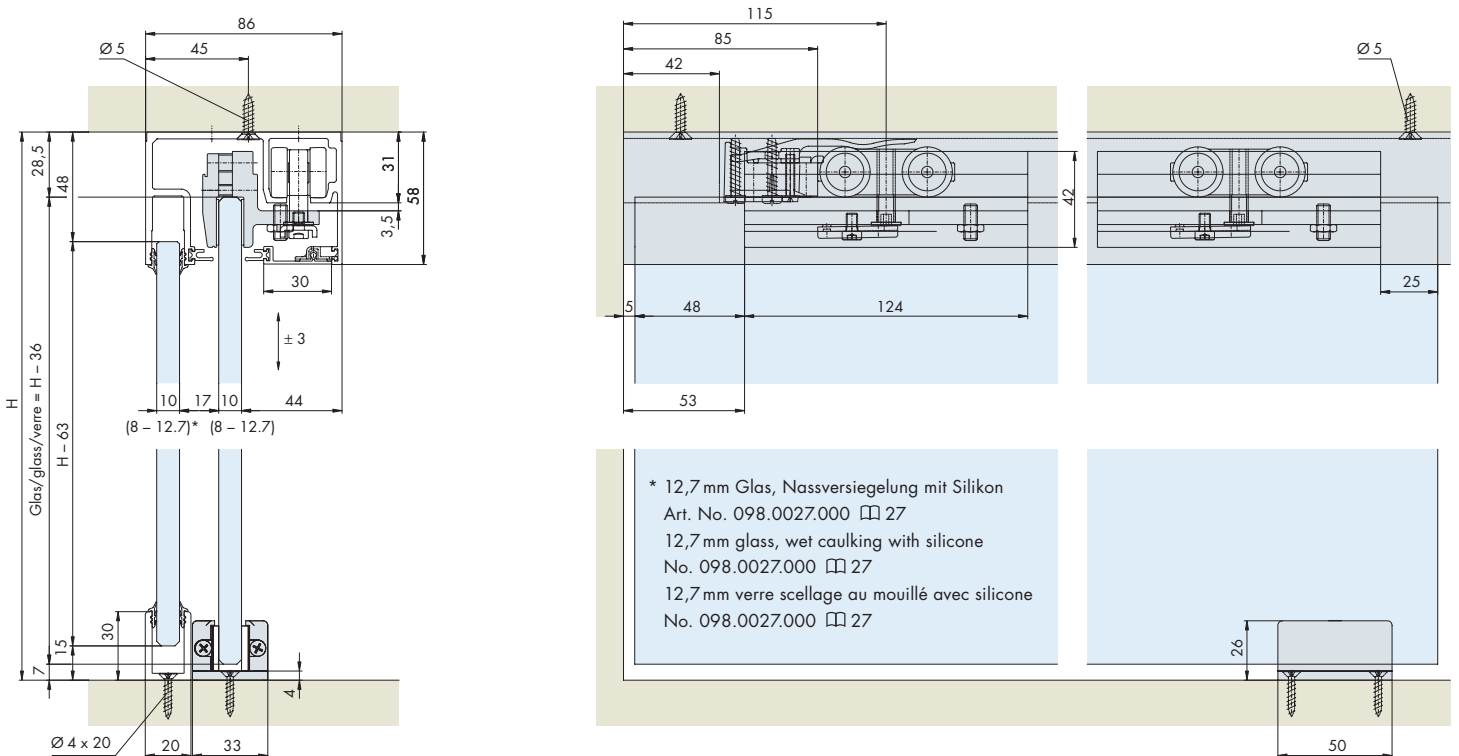

Einbaubeispiel deckenbündig

Mounting example flush with the ceiling

Exemple de montage affleurant avec le plafond

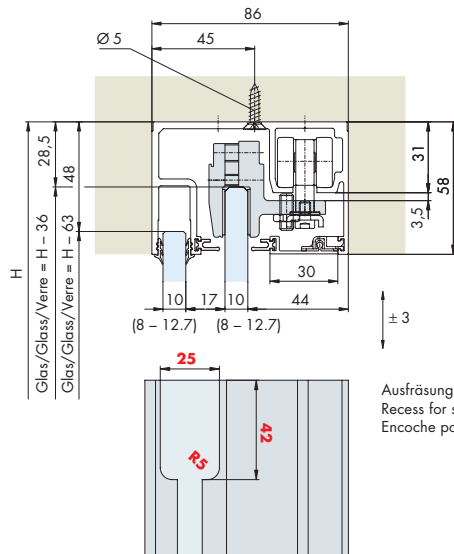

Ausfräsung zum Ein-/Ausfahren Laufwerk und Stopper
Recess for sliding running gear and stop in and out
Encoche pour introduire/sortir le chariot et la butée

Garnituren / Sets / Garnitures

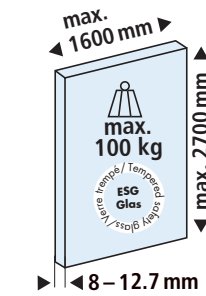

Türgewichte
Door weights
Poids de portes 30

1 Türe Door Porte		No. 057.3091.071	
2x		2x	
		1x	
		1x	
		1x	
		12x	
		1x	

Zubehör / Accessories / Accessoires

Laufschiene Festglas, Alu, gelocht

Running track fixed glass, aluminium, pre-drilled
Rail de roulement vitre fixe, en alu, perforé

Gr./Size

Art. No.

2500 mm	057.3084.250
3500 mm	057.3084.350
6000 mm	057.3084.600*

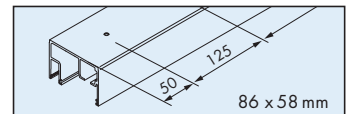

Blendenprofil, Alu, eloxiert

Fascia profile aluminium, anodized
Profil de cache en alu, anodisé

2500 mm	057.3085.250
3500 mm	057.3085.350
6000 mm	057.3085.600*



Stirnprofil, Alu, eloxiert, zu 057.3084

Front edge profile, aluminium, anodized, for 057.3084
Profil à l'avant, en alu, anodisé, pour 057.3084

2500 mm	042.3005.250
3000 mm	042.3005.300
6000 mm	042.3005.600*

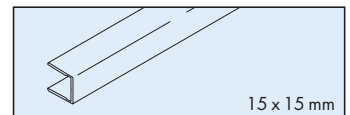

U-Führungsschiene, Alu, eloxiert, gelocht

U-shaped guide track aluminium, anodized, pre-drilled
Rail de guidage en U en alu, anodisé, perforé

2500 mm	057.3056.250
3500 mm	057.3056.350
6000 mm	057.3056.600*

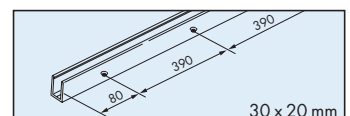

Befestigungs-Set zu Festglashalteprofil / U-Führungsschiene

Fixing set for fixed glass support profile / U-shaped guide track
Jeu de fixation pour porte-vitre fixe / guidage en U

1x 057.3076.071

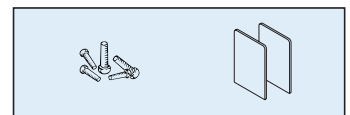

Dichtungsprofil, Kunststoff schwarz, in Rollen

Sealing profile, plastic black, in coils
Profil d'étanchéité en rouleaux, plastique noire

20 m 057.3072.001

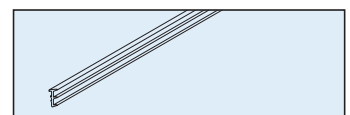

Sichtschutzdichtung, Kunststoff schwarz, in Rollen

Screening seal, black plastic, in rolls
Joint pare-vue, plastique noir, en rouleaux

20 m 057.3078.002

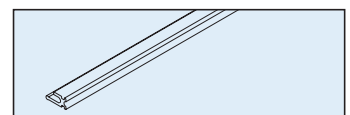

*min. 60 m

Türbearbeitung = rote Zahlen / Dimensions and drillings for door = red numbers / Traitement de portes = chiffres rouges

Sonderzubehör / Special accessories / Accessoires spéciaux: 26-29

EKU PORTA® 100

mod. GW/GWF-Synchro

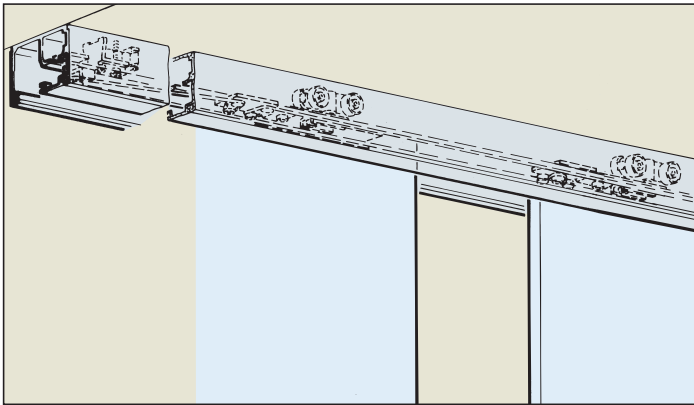

System: Synchro für 2 synchronlaufende Glastüren mit Kevlarseil zu mod. GW/GWF

System: Synchro for 2 synchronized running glass doors with kevlar rope for mod. GW/GWF

Système: Synchro pour 2 portes en verre à roulement synchronisé avec câble kevlar pour mod. GW/GWF

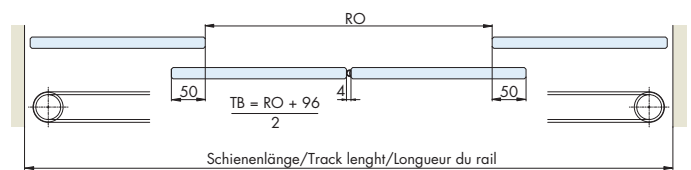
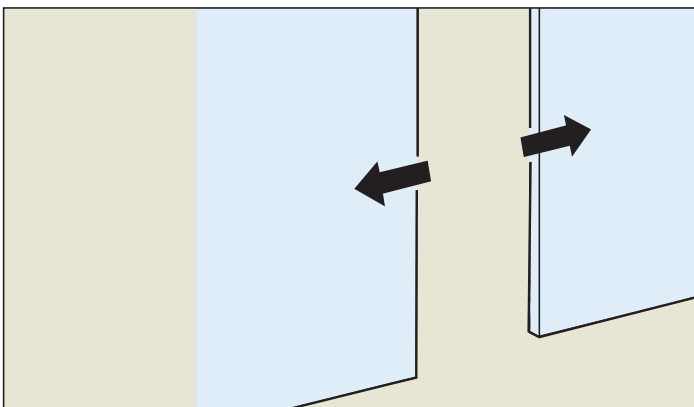

Einbaubeispiele / Mounting examples / Exemples de montage

mod. GW

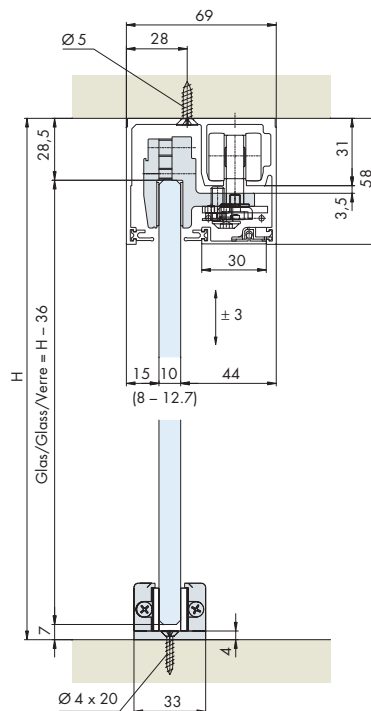

mod. GWF

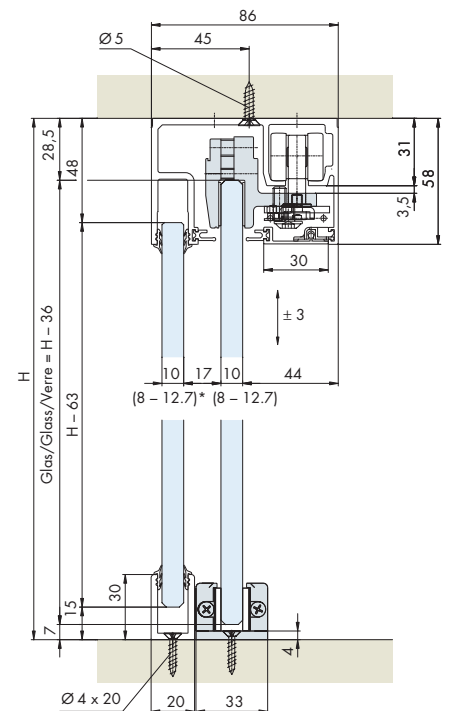

* 12,7 mm Glas, Nassversiegelung mit Silikon
 Art. No. 098.0027.000 □ 27
 12,7 mm glass, wet caulking with silicone
 No. 098.0027.000 □ 27
 12,7 mm verre scellage au mouillé avec silicone
 No. 098.0027.000 □ 27

